

MULTI *Flow*
SMT

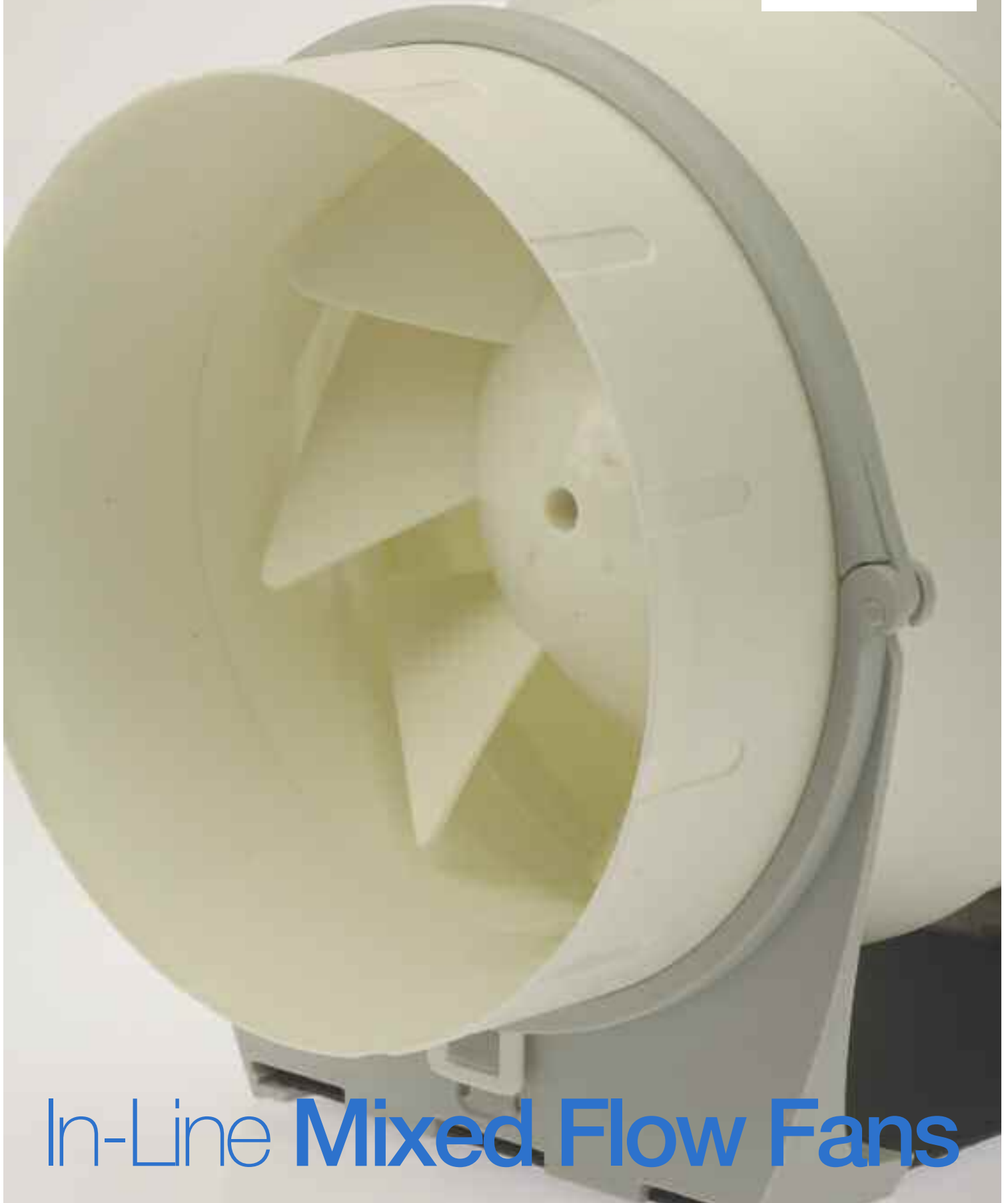

In-Line **Mixed Flow Fans**

Multiflow SMT – In-Line Tube

Features & Benefits



The Multiflow SMT is a range of in-line mixed flow fans with a compact profile which offers excellent pressure development characteristics, designed specifically for use with rigid or flexible ductwork for a wide variety of residential and commercial applications.

- Integral mixed flow impeller design.
- 4 standard sizes from 100mm to 200mm.
- Air volume flow rates of up to 0.233 m³/sec.
- Static pressures of up to 250 Pa.
- Greater pressure capability than axial fans.
- Greater airflow capability than centrifugal fans.
- IPX4 – Splash proof.
- Suitable for operating temperatures up to 60° C.
- Motors are double insulated with built-in thermal overload protection.
- CE Marked.
- Sealed for life ball bearings to operate at any angle.
- Timer adjustable from 3-15 minutes.
- Lower noise levels.

Features & Benefits

Range – There are four sizes, 100mm, 125mm, 150mm and 200mm which can be supplied with or without a run on timer and suitable for continuous running.

Design appeal – The compact design means the SMT is ideal where space is at a premium such as ceiling voids and refurbishment projects.

Ease of installation – SMT fans can be mounted in line or at either end of the ductwork, horizontally or vertically, as well as against walls, ceiling voids and other flat surfaces.

Motor protection – Each SMT motor is double insulated so no earth is required with integral thermal overload protection which prevents the motor from overheating.

Flexibility - Available in all models as a two speed unit from a remote switch to give the installer a range of adjustment if duties are under or over achieving.

Easy to maintain – All SMT models feature a removable motor and impeller body which ensures easier cleaning without affecting the installation by having to remove the ductwork.

Material strength – Units are manufactured from shock proof, heat resistant white plastic, which is durable and non corrosive.

Safety – SMT fans are IPX4 Splash proof, protected against water splashing from all directions which means they can be safely installed in Zones I and II in accordance with Building Regulations.

Full accessory range – Fast clamps, silencers, panel filters, electric heater batteries, flexible connectors and non return dampers.

Reliability – Motors have sealed for life bearings.

Settings – The timer settings are adjustable between 3-15 minutes.

Warranty – Each Multiflow SMT has a two year warranty.

Applications

Shower rooms, bathrooms, kitchens, utility rooms, residential and commercial facilities.

Multiflow SMT - In-Line Tube

Dimensional & Performance Data

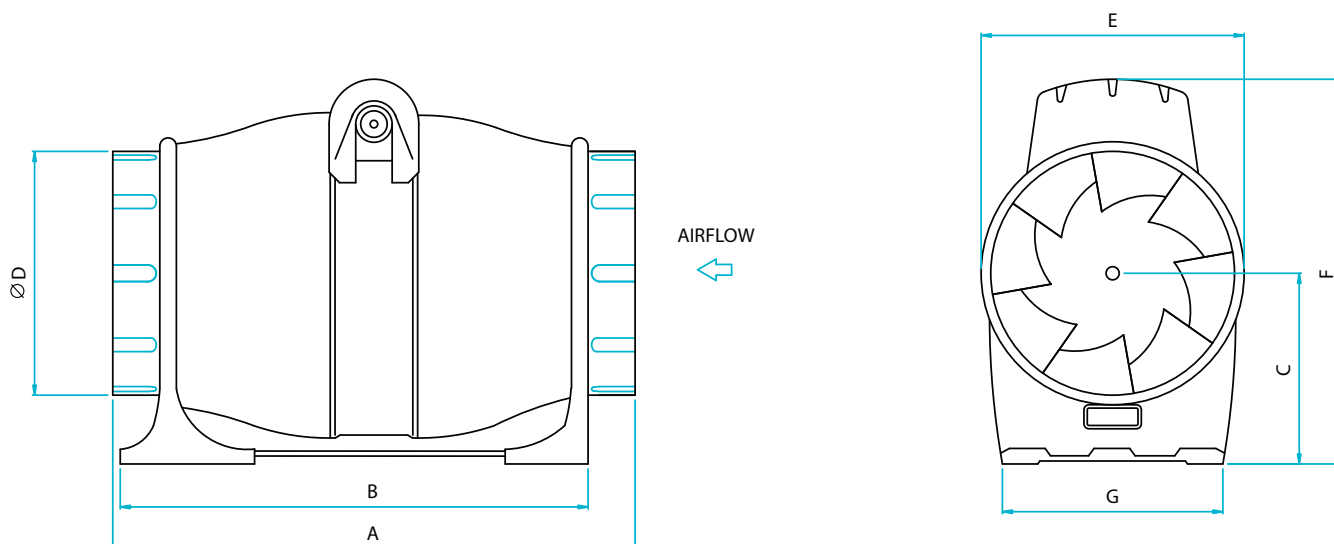

MIXED FLOW

Product Code	A	B	C	D	E	F	G	Weight kg
SMT100	315	235	115	98	180	232	130	3
SMT125	280	235	115	122	180	232	130	3
SMT150	294	265	115	147	192	240	130	3
SMT200	354	265	140	197	230	280	142	4

Product Code	Speed r/min	Airflow m ³ /s @ Static Pressure Pa.											Motor Electrical Data		dBA @ 3m
		0	25	50	75	100	125	150	175	200	225	250	FLC Amps	Input Watts	
SMT100 High	2300	0.070	0.067	0.063	0.059	0.053	0.038	0.024	0.014				0.18	30	42
SMT100 Low	1700	0.056	0.05	0.042	0.028	0.017	0.007						0.10	18	35
SMT125 High	2300	0.076	0.071	0.066	0.059	0.039	0.022	0.012					0.18	30	43
SMT125 Low	1700	0.055	0.049	0.043	0.022	0.008							0.10	18	35
SMT150 High	2700	0.131	0.127	0.122	0.118	0.113	0.108	0.102	0.095	0.082	0.029	0.014	0.36	80	52
SMT150 Low	2000	0.106	0.102	0.098	0.093	0.088	0.080	0.066	0.037	0.019	0.004		0.27	60	48
SMT200 High	2700	0.233	0.224	0.214	0.202	0.189	0.174	0.152	0.104				0.34	85	50
SMT200 Low	2000	0.171	0.14	0.118	0.097								0.24	55	39

Sound levels are average spherical free field values at 50% peak pressure for comparative purposes only.

Multiflow SMT - In-Line Tube

Sound Data



SMT - SINGLE Phase

Product Code		63Hz	125Hz	250Hz	500Hz	1kHz	2kHz	4kHz	8kHz	dBA @ 3m
SMT100 High	Inlet	51	54	62	60	59	52	46	42	42
	Outlet	51	54	62	62	57	51	47	40	42
	Breakout	48	51	56	58	54	48	42	37	38
SMT100 Low	Inlet	48	48	55	55	53	47	41	39	36
	Outlet	47	49	56	55	51	46	41	35	35
	Breakout	46	48	51	53	48	43	37	30	32
SMT125 High	Inlet	47	48	72	61	58	52	48	39	45
	Outlet	45	49	62	62	59	53	49	40	43
	Breakout	46	48	58	56	53	45	39	29	37
SMT125 Low	Inlet	44	47	61	56	51	44	39	30	36
	Outlet	42	48	57	56	51	44	40	29	35
	Breakout	43	44	54	51	45	37	29	24	30
SMT150 High	Inlet	53	54	66	67	66	61	55	49	49
	Outlet	56	56	70	72	69	62	57	51	52
	Breakout	53	55	63	63	61	53	46	39	44
SMT150 Low	Inlet	51	53	65	64	62	58	52	44	45
	Outlet	54	53	67	68	64	59	54	46	48
	Breakout	51	53	62	59	57	51	44	36	40
SMT200 High	Inlet	54	57	70	68	65	63	58	51	50
	Outlet	57	59	70	69	65	63	57	52	50
	Breakout	54	63	67	66	61	57	47	39	46
SMT200 Low	Inlet	50	54	62	60	56	53	47	39	41
	Outlet	53	54	60	59	55	52	46	39	39
	Breakout	54	57	60	60	56	52	47	40	40

Multiflow SMT - In-Line Tube



Performance Curves

SMT100

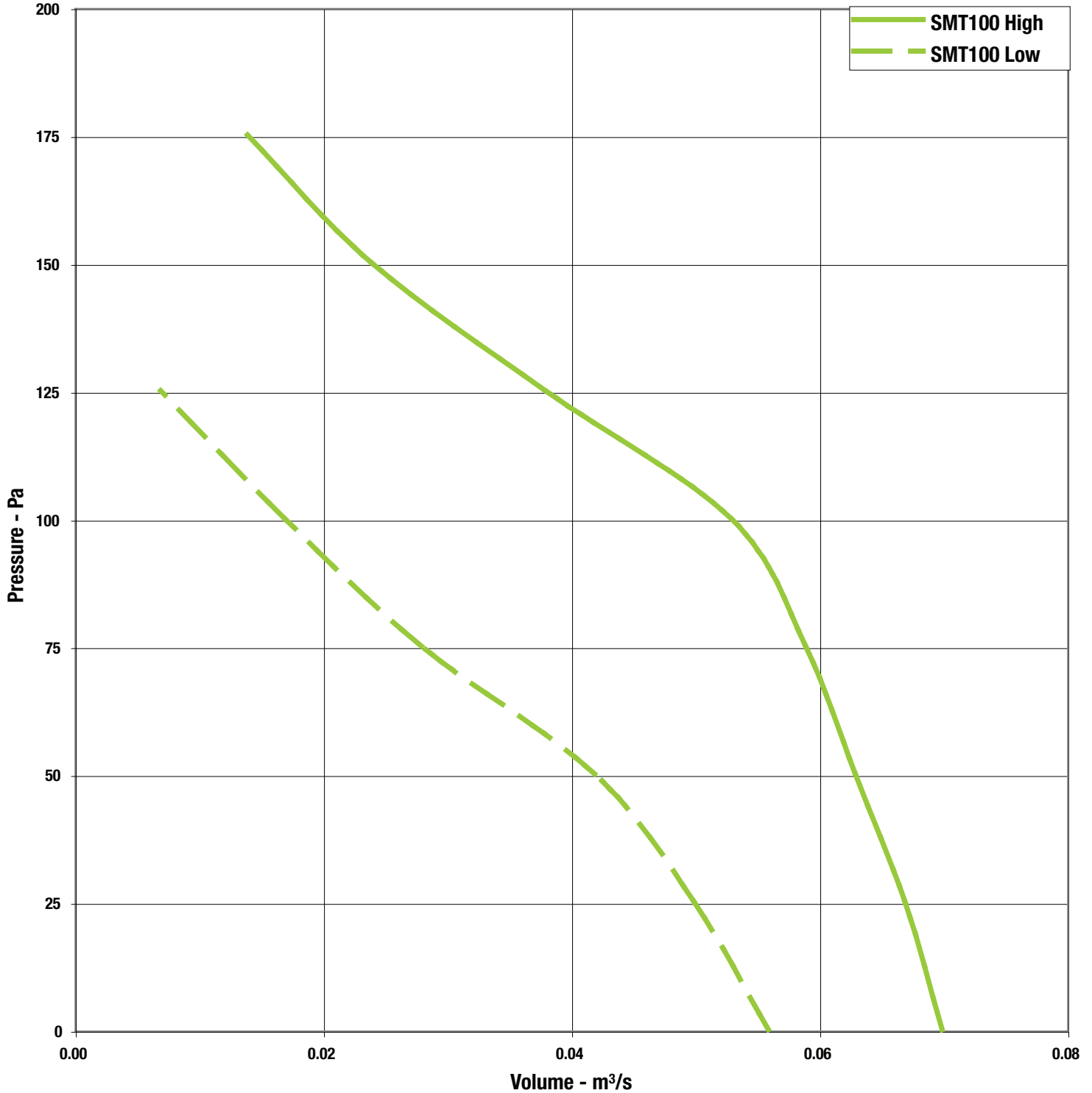

Multiflow SMT - In-Line Tube

Performance Curves



SMT125

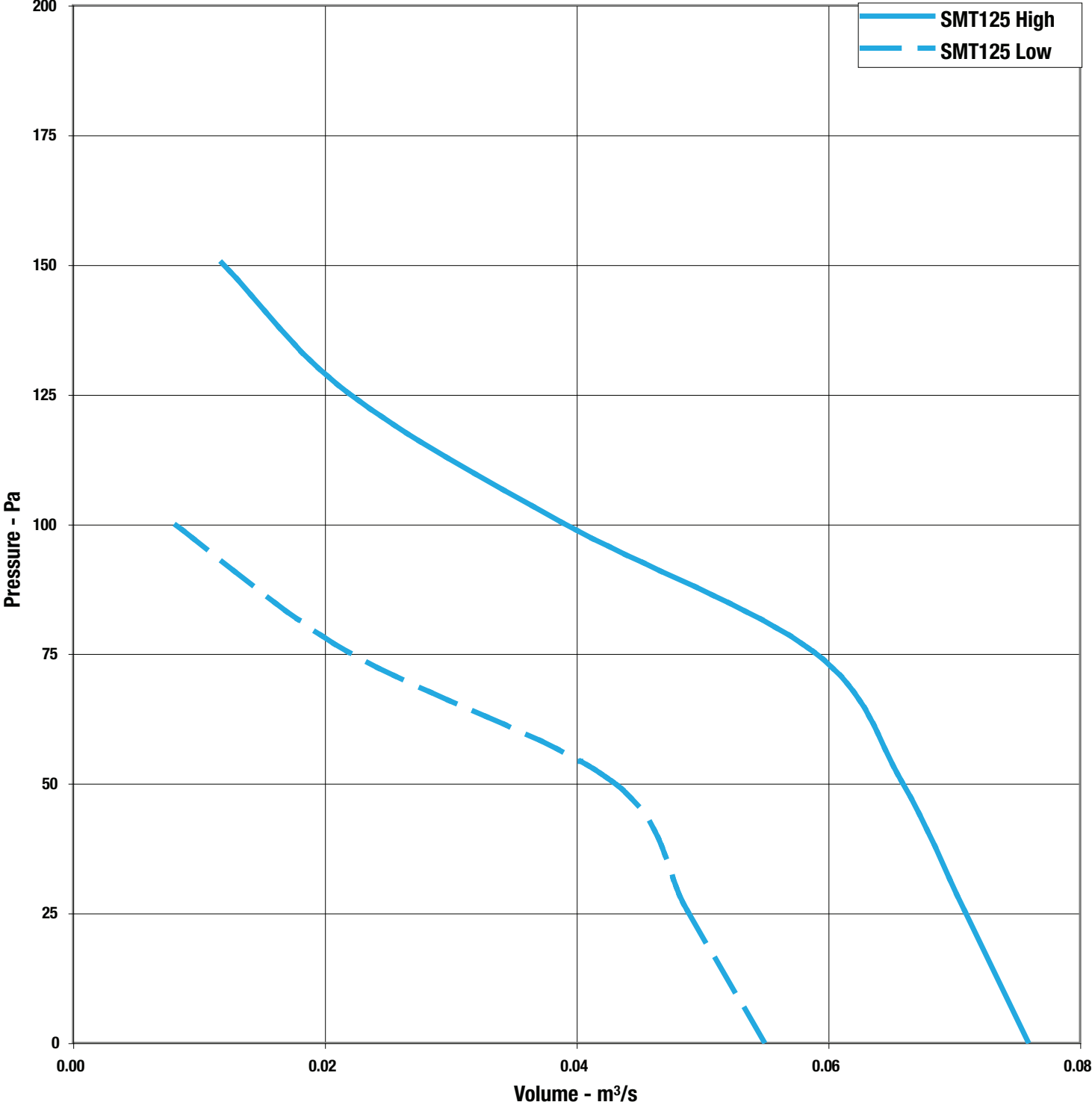

Multiflow SMT - In-Line Tube



Performance Curves

SMT150

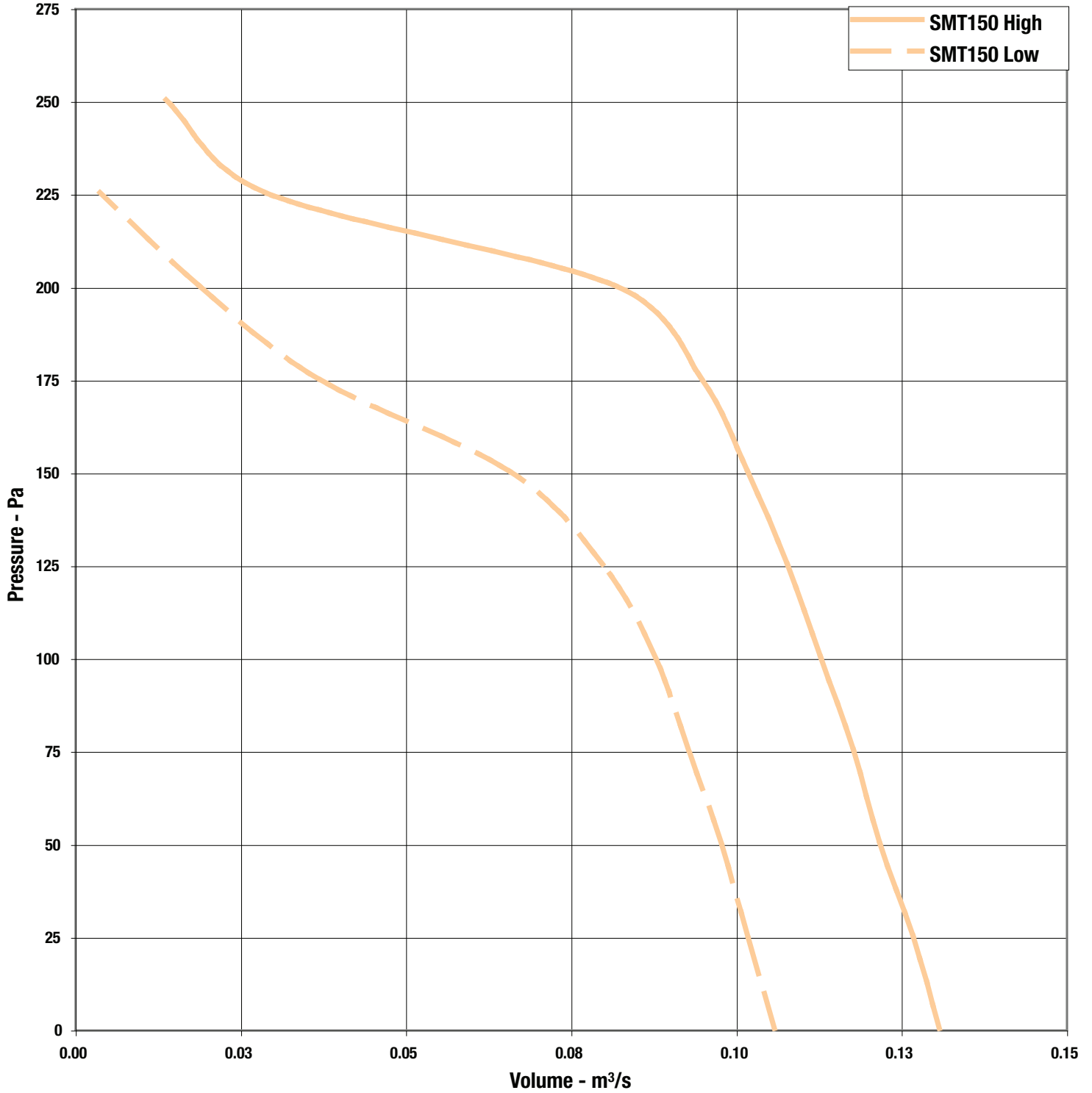

Multiflow SMT - In-Line Tube

Performance Curves



SMT200

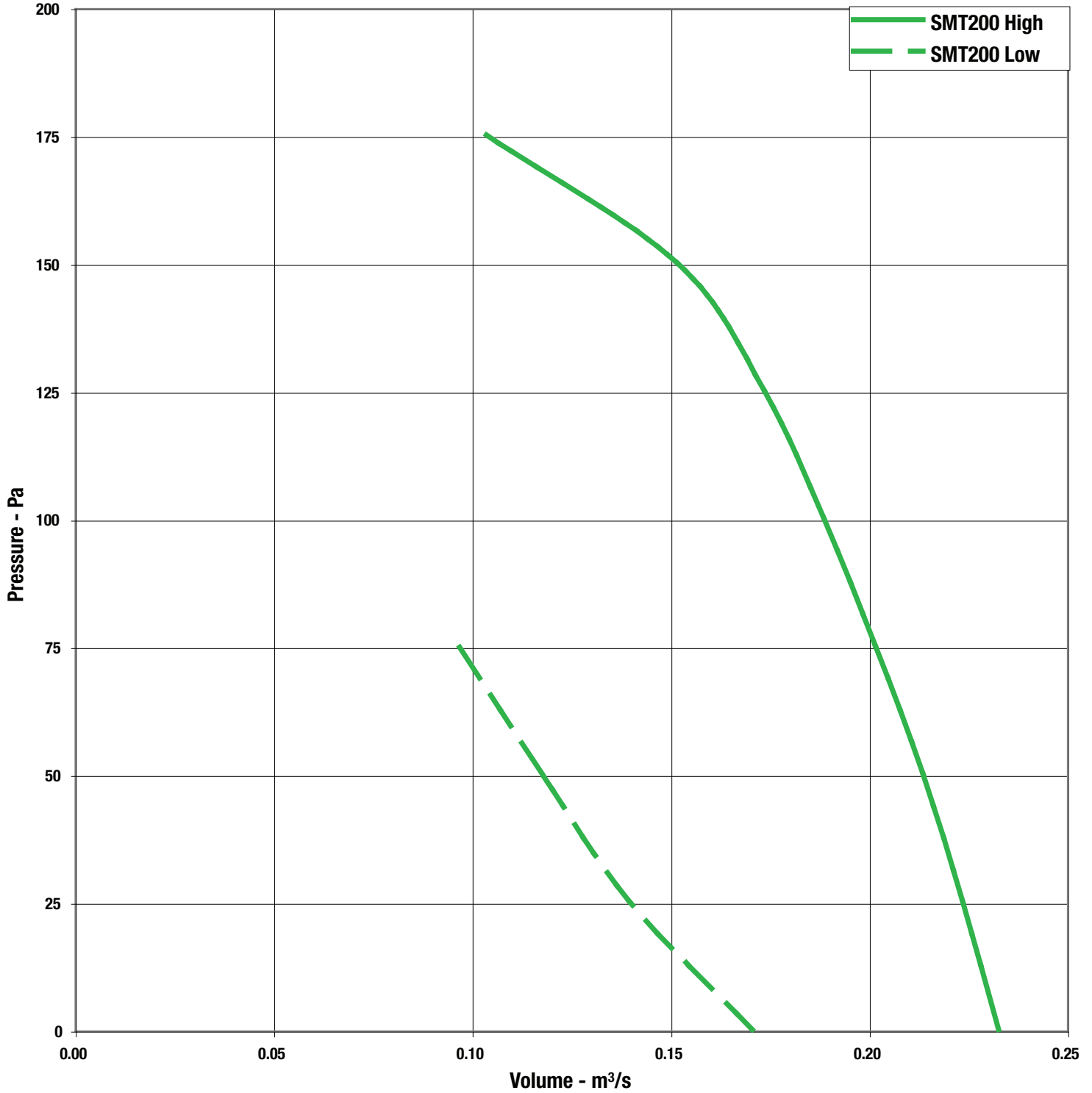

Multiflow SMT - In-Line Tube Accessories



Flexible Connectors

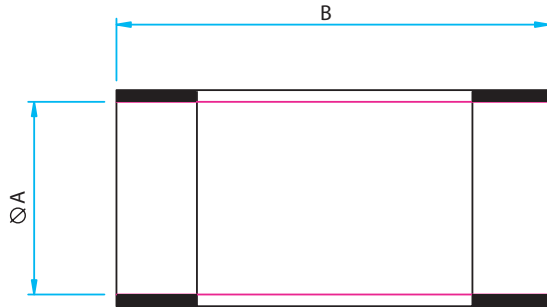

- Fix directly onto spigot
- Provides flexible connection between fan and accessory or duct
- PVC coated polyester with galvanised sheet steel

Product Code	Fan Dia. A	B	Weight kg
018-0100-FLEX	100	150	0.2
018-0125-FLEX	125	150	0.2
018-0150-FLEX	150	150	0.2
018-0200-FLEX	200	150	0.3

MIXED FLOW

Silencers

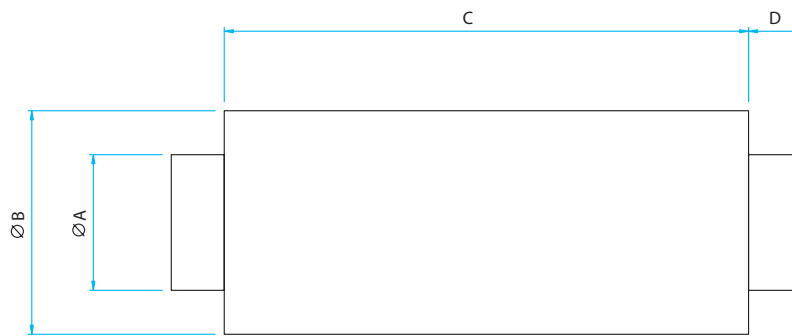

- For information on silencers and an explanation of the data, see p74
- Pre-galvanised sheet steel with perforated steel lining
- Infill of glass tissue faced high density mineral wool
- For saturated or other special applications please refer to Elta

Product Code	Fan Dia.	A	B	C 1	C 2	C 3	C 4	D	Weight kg			
									1	2	3	4
068-0100-JF*	100	98	204	300	600	900	1200	40	2.5	4.6	6.7	8.7
068-0125-JF*	125	123	230						2.9	5.4	7.8	10.2
068-0150-JF*	150	148	255						3.4	6.1	8.9	11.6
068-0200-JF*	200	198	305						4.2	7.6	11.0	14.5

* Add 1, 2, 3 or 4 depending on length required.

Non Return Dampers

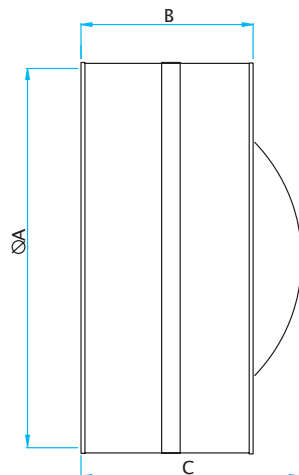

- Prevents reverse flow of air when fan not operating
- Galvanised sheet steel case
- Spring operated, aluminium sheet blades

Product Code	Fan Dia. A	B	C	Weight kg
018-100-DAMPER	100	90	100	0.2
018-125-DAMPER	125	90	100	0.3
018-150-DAMPER	150	90	110	0.3
018-200-DAMPER	200	125	150	0.6

Multiflow SMT - In-Line Tube Accessories



Fast Clamps

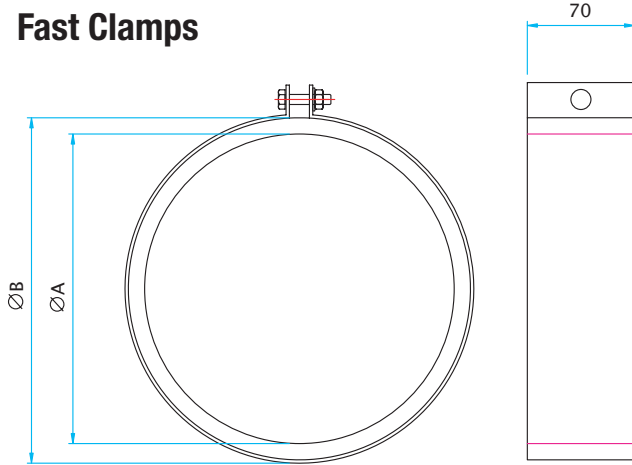

- For quick connection of spigotted fans to circular duct or accessories
- Galvanised steel circular duct clamp with foam lining

Product Code	Fan Size	A	B	Weight kg
018-100-CLAMP	100	92	116	0.25
018-125-CLAMP	125	117	141	0.29
018-150-CLAMP	150	142	166	0.33
018-200-CLAMP	200	192	216	0.42

Electric Heater Batteries

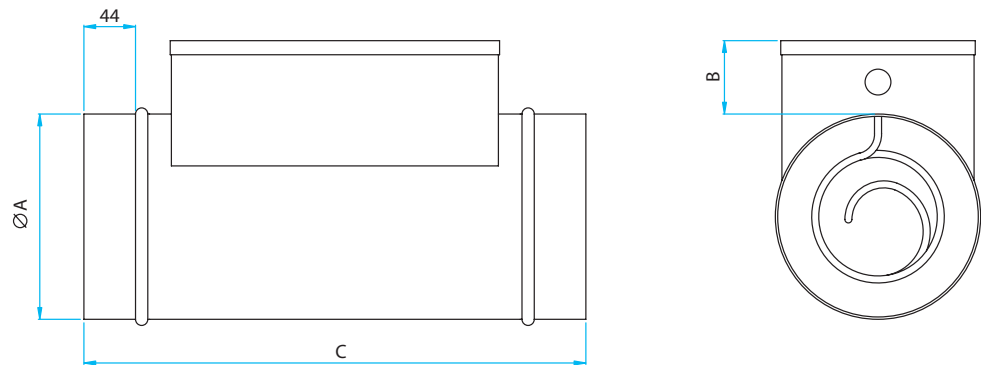

Product Code	kW	Stage	Phase	Air Flow @ m3/s		A	B	C	Weight kg
				Min	Max				
018-0100-HEAT-1	0.75	1	1	0.016	0.047	100	55	400	2
018-0125-HEAT-1	1.0	1	1	0.025	0.074	125	80	400	2
018-0150-HEAT-1	1.5	1	1	0.035	0.106	150	80	400	3
018-0200-HEAT-1	2.0	1	1	0.063	0.189	200	80	400	4

- Safe and clean heating
- Max exit temperature is 40°C at 70% RH
- Galvanised sheet steel case
- Elements are nickel chromium wire insulated by compacted magnesium oxide powder within a stainless steel or incoloy tube and sealed by ceramic bead and silicon sealant
- Air velocity min 2m/s, max 6m/s
- Fitted with manual reset high temperature cutout

Panel Filters

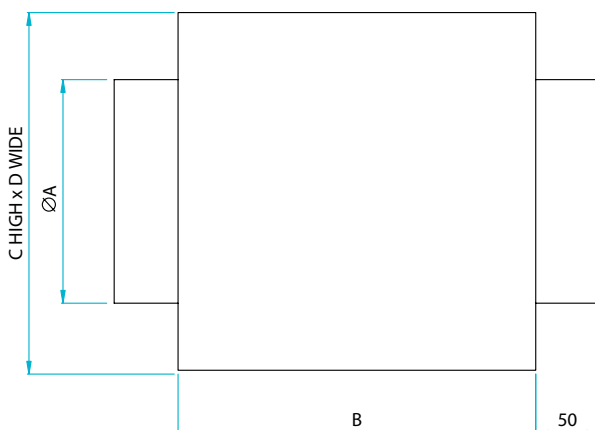

- Galvanised steel casing
- Filter media to BS EN 779 rating G3 with 85% arresstance
- Filter access with removable panel

Product Code	Fan Dia. A	B	C	D	Weight kg
018-0100-FILT-P	100	155	200	200	2
018-0125-FILT-P	125	155	200	200	2
018-0150-FILT-P	150	155	250	250	2
018-0200-FILT-P	200	155	250	250	2

MIXED FLOW



Elta Fans Ltd - Applied Technology

17 Barnes Wallis Road,
Segensworth East Industrial Estate,
Fareham, Hampshire, P015 5ST, United Kingdom.

Visit: eltafans.com

e-mail: mailbox@eltafans.co.uk

Applied Technology:

Tel: +44 (0) 1489 566500

Fax: +44 (0) 1489 566555

Building Services:

Tel: +44 (0) 1384 275800

Fax: +44 (0) 1384 275810

Export:

Tel: +44 (0) 1489 566500

Fax: +44 (0) 1489 566555