

EZI-FIT



In-Wall & Thru Wall
Centrifugal Fans

Ezifit In-Wall SEIE

Features & Benefits



The Ezifit In-Wall unit is a flush mounted fan that's ideal where a ceiling or in-line fan is impractical – such as kitchen canopies, or ducted exhaust systems between floors in residential applications, or through flat roof applications where quiet, powerful exhaust is required and space is limited.

- Flush mounted.
- Easy to install.
- Compact design for installation in tight spaces.
- Powerful extract.
- Colour co-ordinated external grilles.
- Suitable for operating temperatures up to 50°C.
- Thermal overload motor protection.
- Can be wired in High, Medium or Low speed.
- 3-Speed Switch available for remote speed control.
- Neutral colour plastic grille to compliment most brick colours.

Features & Benefits

Ease of installation – The Ezifit In-Wall unit is designed to install on an exterior wall and its compact design allows installation in tight spaces.

Design appeal – The flush mounted design provides an unobtrusive appearance.

Flexibility – A three speed backward curved centrifugal impeller increases the flexibility by allowing the desired speed setting to be selected either at the time of installation or by an optional remote mounted three speed switch.

Performance – Ezifit In-Wall units provide powerful air extraction and are suitable for single or multi point extract.

Insect proof – Fly mesh is fitted to the inside of the grille as standard to keep out insects.

Colour co-ordination – The robust neutral coloured external plastic grille is designed to suit most brick colours.

Safety – The external rotor motors are all fitted with integral thermal overload protection preventing the motor from overheating.

Accessories - Three speed switch, fast clamps and silencers.

Warranty - Each SEIE has a 12 month warranty.

Applications

Domestic kitchen range hood exhaust, bathrooms, laundries, clothes dryer venting, sub floor ventilation and smaller commercial installations.

Ezifit In-Wall SEIE

Dimensional & Performance Data

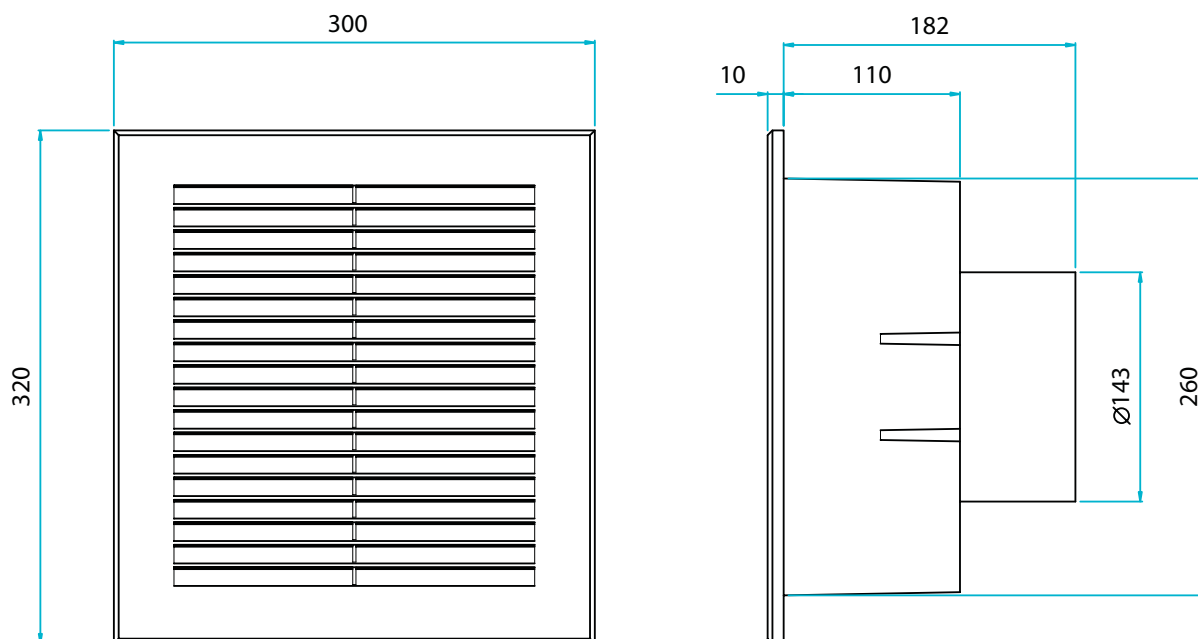

Product Code	Speed r/min	Airflow m ³ /s @ Static Pressure Pa.										FLC Amps	Power Watts	dBA@ 3m	Weight kg
		0	25	50	75	100	125	150	175	200	225				
LOW	1260	0.081	0.050	0.036	0.028	0.021	0.015					0.22	50	31	4
SEIE150 MED	1920	0.117	0.099	0.082	0.068	0.055	0.044	0.034	0.024	0.016		0.25	60	44	
HIGH	2400	0.151	0.134	0.120	0.105	0.092	0.080	0.070	0.060	0.048	0.030	0.29	75	49	

Sound levels are average spherical free field values for comparative purposes only.

Accessories



Ezifit In-Wall SEIE

Performance Curves



SEIE 150

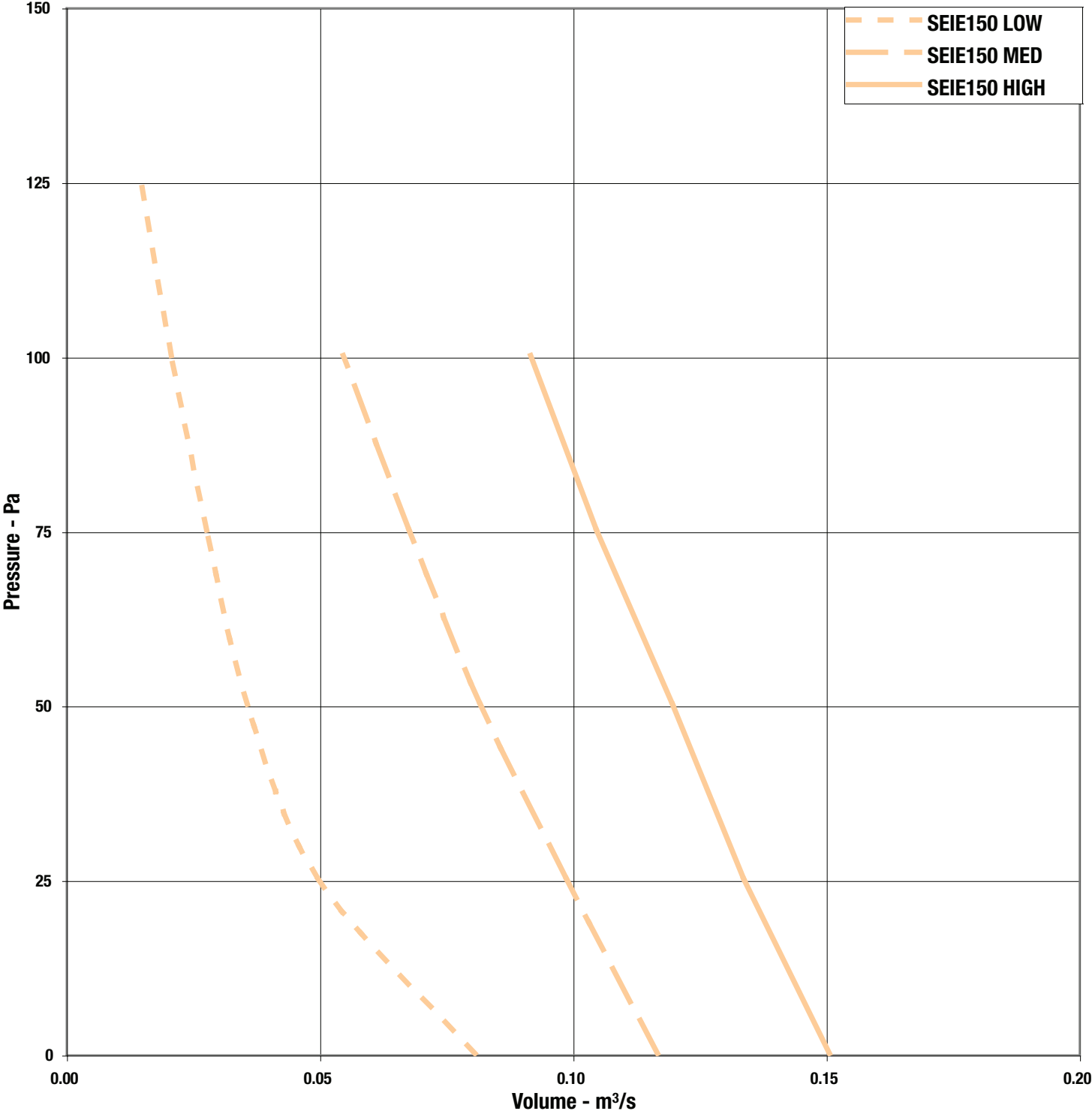

Ezifit Thru-Wall SEWE

Features & Benefits



The Ezifit Thru-Wall unit is a surface mounted fan which is specifically developed in response to the need for a fan that does not take up internal space and is suited to ducted systems where space is restricted such as between floors in residential applications.

- Easy to install on exterior wall.
- Stylish, compact design for installation in tight spaces.
- Lightweight, durable construction.
- Powerful air extract.
- Suitable for applications requiring long lengths of duct.
- Suitable for operating temperatures up to 50°C.
- Insect proof cover.
- Easy access for cleaning.
- Can be used with variable speed controller.
- Thermal overload motor protection.

Features & Benefits

Ease of installation – The surface mounted Ezifit Thru-wall unit is designed for simple installation by mounting it on the exterior wall and its compact design allows installation in tight spaces.

Flexibility – The Ezifit Thru-Wall unit can be used with a variable speed controller.

Range – The range comprises both four pole and two pole speed fans with four pole models particularly suited to single point through wall 'no duct' or short duct applications.

Maintenance – The surface mounted cover is easily removed for cleaning, for example, if used for range hood exhaust.

Performance – Ezifit Thru-Wall units comprise backward curved centrifugal impellers which provide powerful air extraction suitable for multi point extract, but is also quiet enough for a single point system with a few metres of flexible duct between the fan and grille.

Insect proof – The unit is fitted with an insect proof cover with fly mesh fitted to the outlet.

Colour co-ordination – The standard unit has a stylish grey colorbond finish and is designed to suit most brick colours.

Safety – The external rotor motors are all fitted with integral thermal overload protection preventing the motor from overheating.

Accessories - Three speed switch, fast clamps and silencers.

Warranty - Each SEWE has a 12 month warranty.

Applications

Domestic kitchen range hood exhaust, bathrooms, laundries, clothes dryer venting, sub floor ventilation and smaller commercial installations.

Ezifit Thru-Wall SEWE

Dimensional & Performance Data

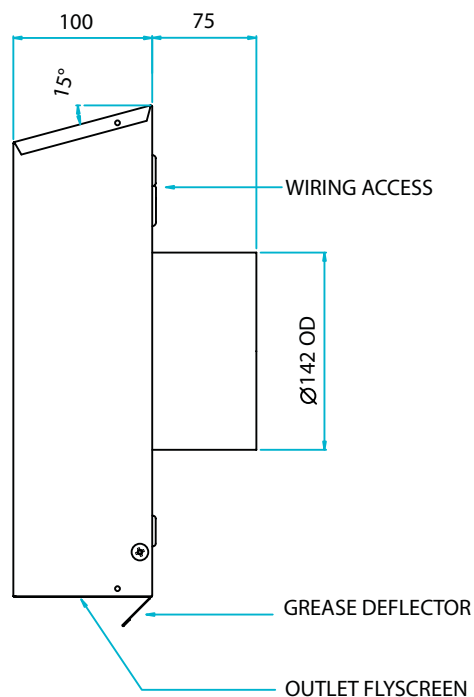
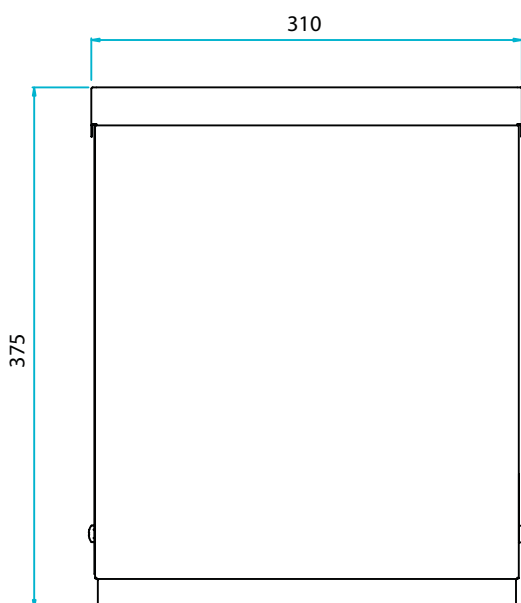

Product Code	Speed r/min	Airflow m ³ /s @ Static Pressure Pa.												FLC Amps	Power Watts	dBA@ 3m	Weight kg
		0	25	50	75	100	125	150	175	200	225	250	275				
SEWE154	1380	0.067	0.056	0.043	0.025									0.16	34	34	5
SEWE152	2460	0.124	0.117	0.110	0.102	0.094	0.086	0.077	0.068	0.058	0.048	0.037	0.024	0.30	65	45	5

Sound levels are average spherical free field values for comparative purposes only.

Accessories



SEWE - SINGLE Phase

Product Code	63Hz	125Hz	250Hz	500Hz	1kHz	2kHz	4kHz	8kHz	dBA @ 3m
SEWE152	61	60	66	65	61	57	52	42	45
SEWE154	53	52	57	55	48	43	36	27	34

Ezifit Thru-Wall SEWE



Performance Curves

SEWE

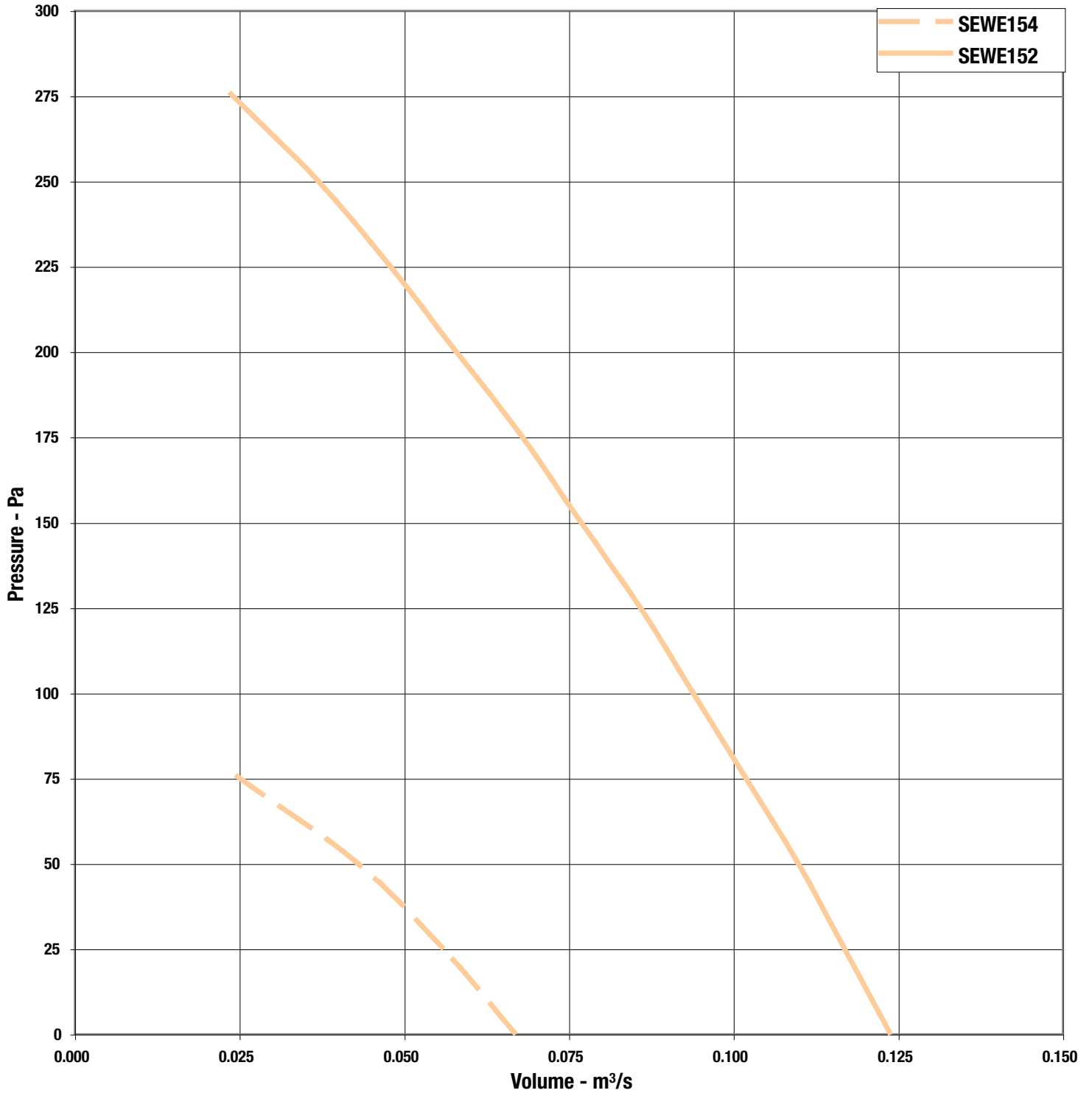

Ezifit Thru-Wall SEWE Accessories

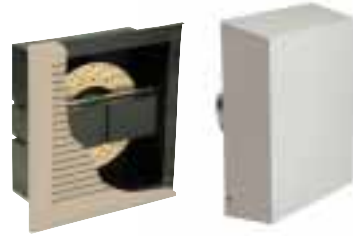

Silencers

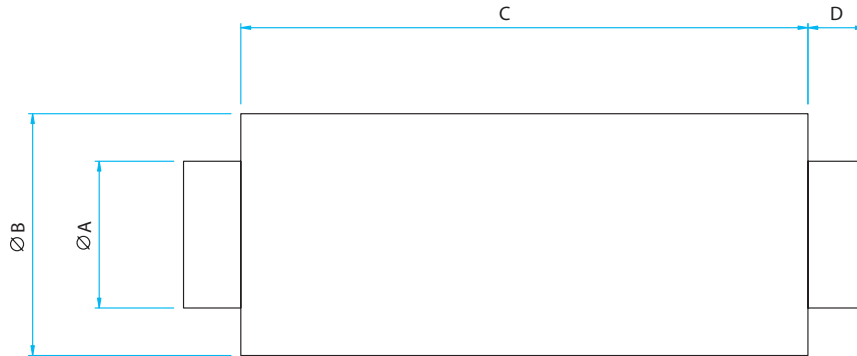

- For information on silencers and an explanation of the data, see p74
- Pre-galvanised sheet steel with perforated steel lining
- Infill of glass tissue faced high density mineral wool
- For saturated or other special applications please refer to Elta

Product Code	Fan Size	A	B	C 1	C 2	C 3	C 4	D	Weight kg			
									1	2	3	4
068-0150-JF*	150	148	255	300	600	900	1200	40	3.4	6.1	8.9	11.6

* Add 1, 2, 3, 4 depending on length required.

Fast Clamps

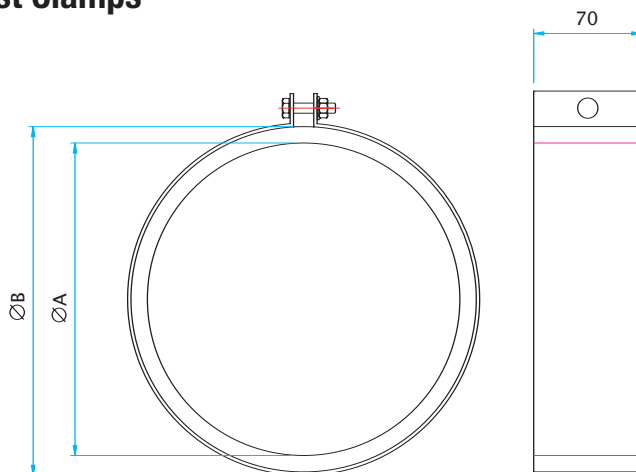

- For quick connection of spigotted fans to circular duct or accessories
- Galvanised steel circular duct clamp with foam lining

Product Code	Fan Size	A	B	Weight kg
018-150-CLAMP	150	142	166	0.33



Elta Fans Ltd - Applied Technology

17 Barnes Wallis Road,
Segensworth East Industrial Estate,
Fareham, Hampshire, P015 5ST, United Kingdom.

Visit: eltafans.com

e-mail: mailbox@eltafans.co.uk

Applied Technology:

Tel: +44 (0) 1489 566500

Fax: +44 (0) 1489 566555

Building Services:

Tel: +44 (0) 1384 275800

Fax: +44 (0) 1384 275810

Export:

Tel: +44 (0) 1489 566500

Fax: +44 (0) 1489 566555