

# COMPACT **POWER PLUS**

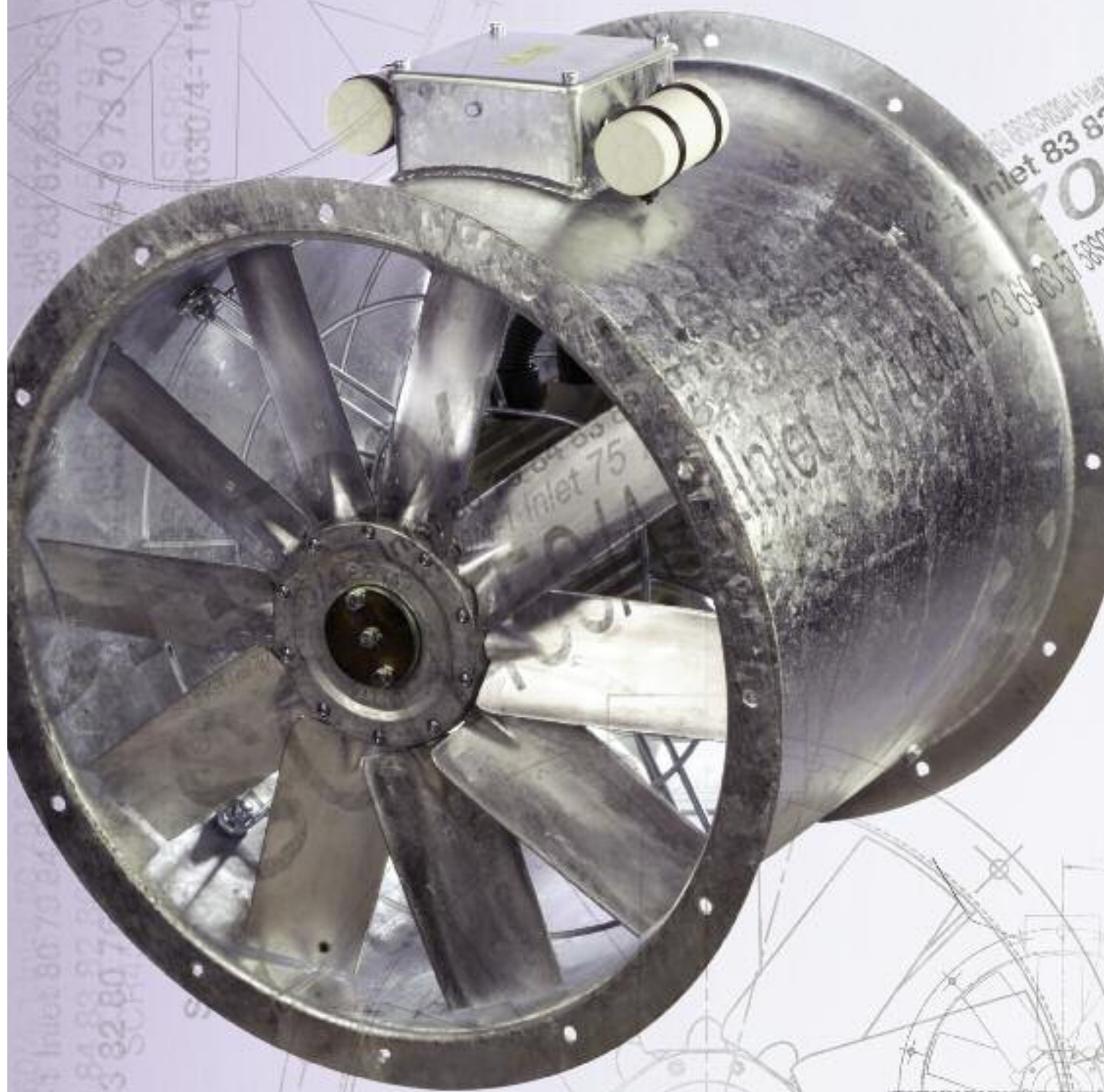

High Pressure **Axial Fans**

# COMPACT POWERPLUS

## introduction

The Compact 'Power Plus' is specifically developed for high pressure requirements that are not suited to single stage fans, with particular emphasis on commercial kitchen extract applications, where the regulations for greater efficiency in kitchen filtration systems, such as the use of Carbon and Baffle filters, have established the need for higher pressure development fans operating at higher working temperatures.

The Contra-Rotating design ensures these fans provide significantly higher performance, without the proportionate increases in noise levels and operating costs – when compared with the same number of single stage booster fans installed in a ducted system.



## features & benefits

The Compact 'PowerPlus' Contra-Rotating range offers an economical, straightforward ventilation solution, by achieving the additional performance requirements beyond those provided by single stage fans.

Pressure developments are typically 3 times higher from the Compact 'PowerPlus' when compared against ELTA single stage models, since the second stage fan is fed by a pre-rotating air supply which means it dramatically cuts the workload for this fan.

The Compact 'PowerPlus' range has a robust construction for added strength and durability.

The design and construction of the fan provides a compact unit, with motors and impellers housed in one comparatively short casing length, which means the unit is easier to handle and install than conventional two staged fans.

The Compact 'PowerPlus' comprises four standard sizes 450mm, 500mm, 560mm and 630mm diameter, with an extensive duty range of between 1.8 m<sup>3</sup>/sec up to 4.3 m<sup>3</sup>/sec when in operation.



# features & benefits

Compact 'PowerPlus' models provide static pressures of up to 600 Pa.

Suitable for operation in up to 95% relative humidity.

Fully speed controllable fans which means flexibility in performance.

The straight through configuration makes the Compact Power Plus easier to fit.

Lower noise level characteristics through the elimination of guide vanes, unnecessary in a Contra-Rotating fan design.

The fan casing is hot dipped galvanised to BS 729 and suitable for external mounting.

Slower impeller tip speeds, which are typically 2 times less than for comparable single stage fans – also assists in reducing noise levels.

A single terminal box, mounted on the outside of the casing, ensures easier, faster wiring of the unit compared with two separate terminal box arrangements.

The SCPP has been introduced to satisfy the requirements of DW172.





# COMPACT PLUS

## specification

### casing

The all metal fan casing provides a long lasting and robust construction. The units have been constructed from a single sheet of steel, with both motors and axial impellers mounted within the length of the unit casing.

All casing parts are heavy gauge mild steel sheet, roll formed and welded, then hot dipped galvanised to BS 729 after fabrication.

### impeller

Adjustable pitch aerofoil impellers are provided with blades made from high quality pressure die cast aluminium (LM6), natural finish.

Impellers are factory set at an angle to provide maximum performance. The hubs are manufactured from die cast aluminium alloy (LM24).

Assembled impellers are to be dynamically balanced to Grade G6.3.

### motors

Motors are highly efficient, lightweight induction motors with sealed for life, maintenance free ball bearings, which allows the fan to be installed at any angle. Each motor is matched to the aerodynamic performance of the impeller. Motors are Class F insulated to EN 60034-5, weatherproofed to IP55 and all suitable for speed control. Each motor has integral thermal overload protection.

Fans are suitable for operating temperatures between -20°C and +70°C fixed speed and -20°C and +50°C when used with a speed controller.

Electrical connection to the motor is provided by an IP55 terminal box which is fitted onto the outer side of the fan casing.

### quality management

Units are to be designed and manufactured with procedures as defined in BS EN ISO 9001: 2000.

All SCPP units are to be tested to ISO 5801:1997 (airside performance) and BS 848 Part 2 : 1985 (sound performance).

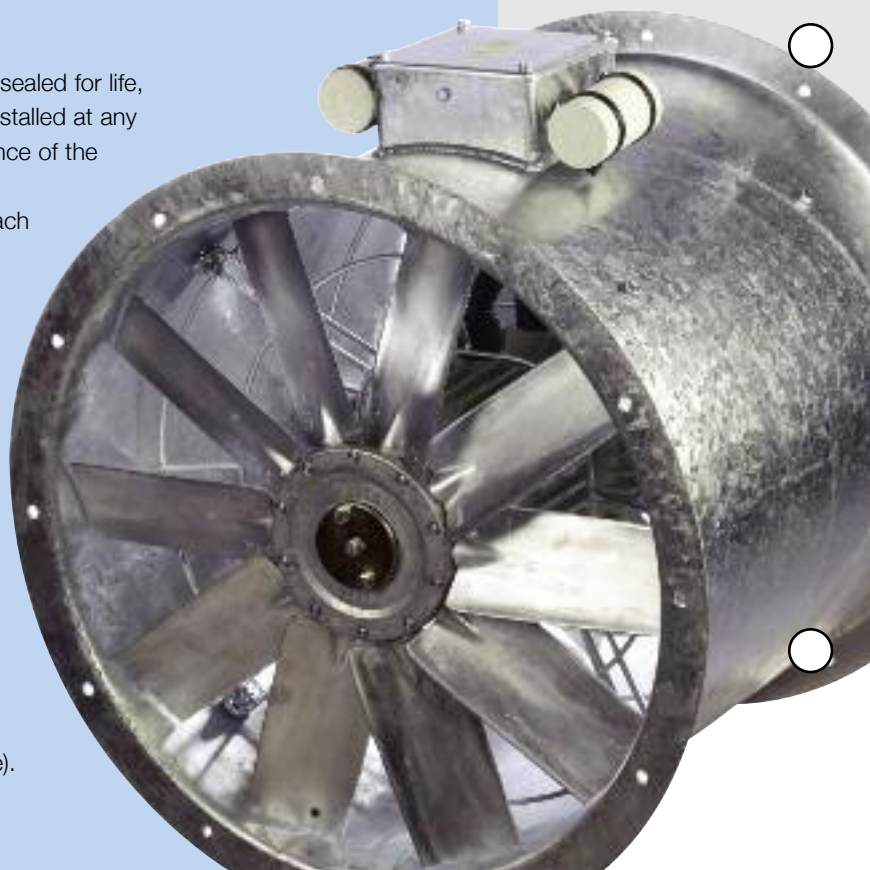

# performance data

Product Code	m <sup>3</sup> /s @ Pa												
	0	50	100	150	200	250	300	350	400	450	500	550	600
SCPP450/4-1	1.80	1.73	1.67	1.60	1.51	1.41	1.27	1.13					
SCPP500/4-1	2.37	2.30	2.24	2.17	2.09	2.01	1.91	1.77	1.61				
SCPP560/4-1	3.19	3.11	3.01	2.91	2.80	2.67	2.51	2.32	2.05	1.69	1.30	1.02	
SCPP630/4-1	4.29	4.18	4.06	3.94	3.81	3.66	3.49	3.28	3.01	2.68	2.30	1.89	1.45

# performance curves

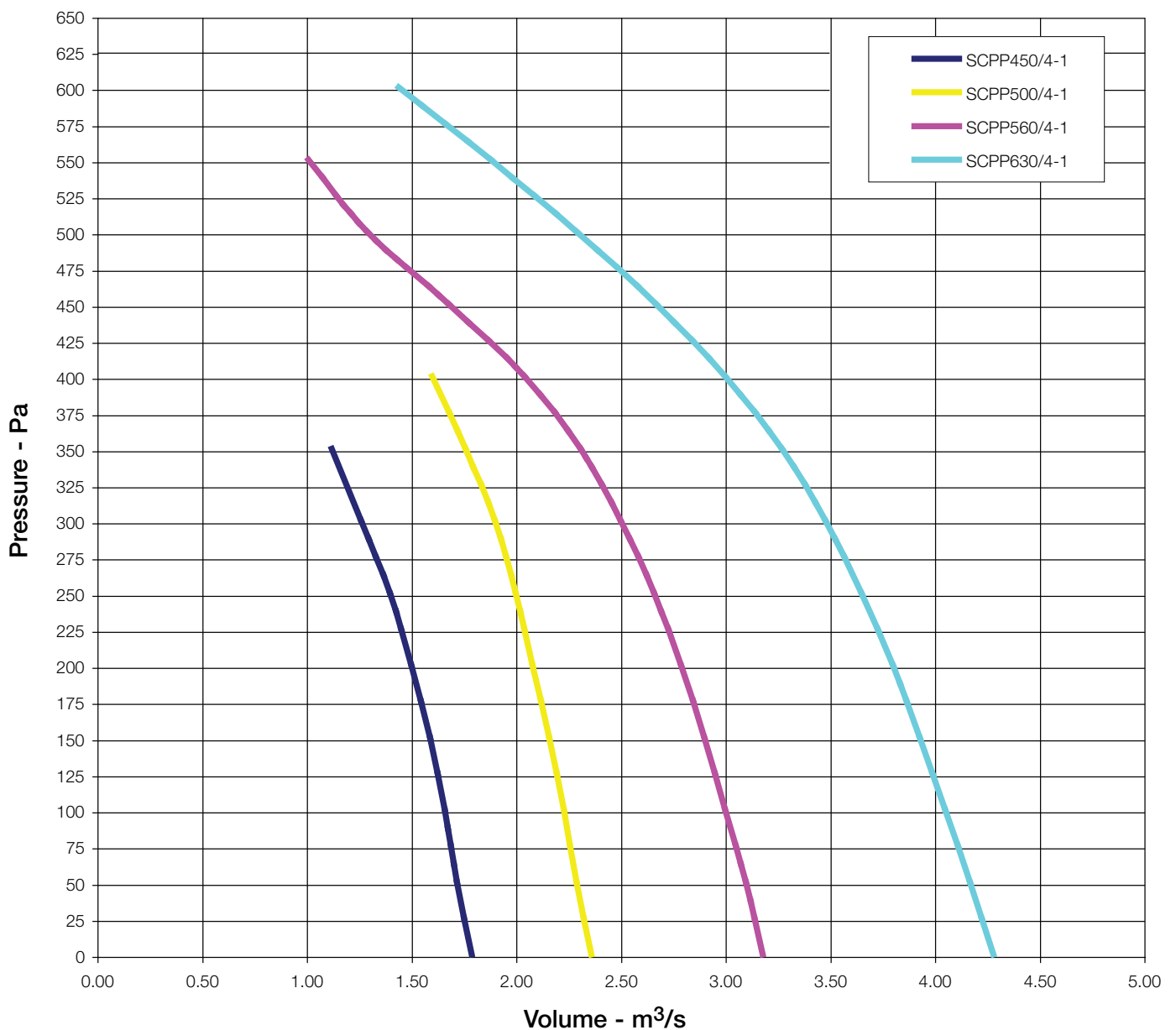

Air data: All units are tested to ISO 5801:1997. As with any fan unit, the actual performance depends on proper mounting, please ask for assistance if you are unsure which unit you require for your application.

# electrical data

Product Code	Speed r/min	FLC Amps	SC Amps	Output kW	Electronic Controller	Transformer Controller
SCPP450/4-1	1345	6.0	18	0.74	EL61TK	TC18
SCPP500/4-1	1350	7.2	21.6	1.1	EL101	TC18
SCPP560/4-1	1350	9.8	30	1.5	-	TC110
SCPP630/4-1	1350	15.8	39.6	2.2	-	-

# sound data

Product Code		Octave Band								dBA @ 3m
		63 Hz	125 Hz	250 Hz	500 Hz	1 kHz	2 kHz	4 kHz	8 kHz	
SCPP450/4-1	Inlet	70	71	80	77	73	69	63	57	58
	Outlet	69	71	80	75	74	71	67	60	58
SCPP500/4-1	Inlet	75	75	82	80	78	75	70	63	62
	Outlet	76	76	82	79	79	77	73	67	63
SCPP560/4-1	Inlet	80	79	84	83	82	80	76	69	66
	Outlet	82	80	84	84	83	82	79	72	68
SCPP630/4-1	Inlet	83	83	87	88	85	83	79	73	70
	Outlet	85	83	87	88	86	86	82	77	71

Acoustic data: tests and preparation of data have been carried out in accordance with BS848 Part 2(1985). The In-duct Sound Power Level Spectra are in dB re 1pW. The overall A-Scale sound pressure level is at a distance of three metres with spherical propagation. It is expressed in dB re 20uPa and is presented for comparative purposes only as in practice the semi-reverberant nature of any installation and directivity effects can give a different level.

# dimensional data

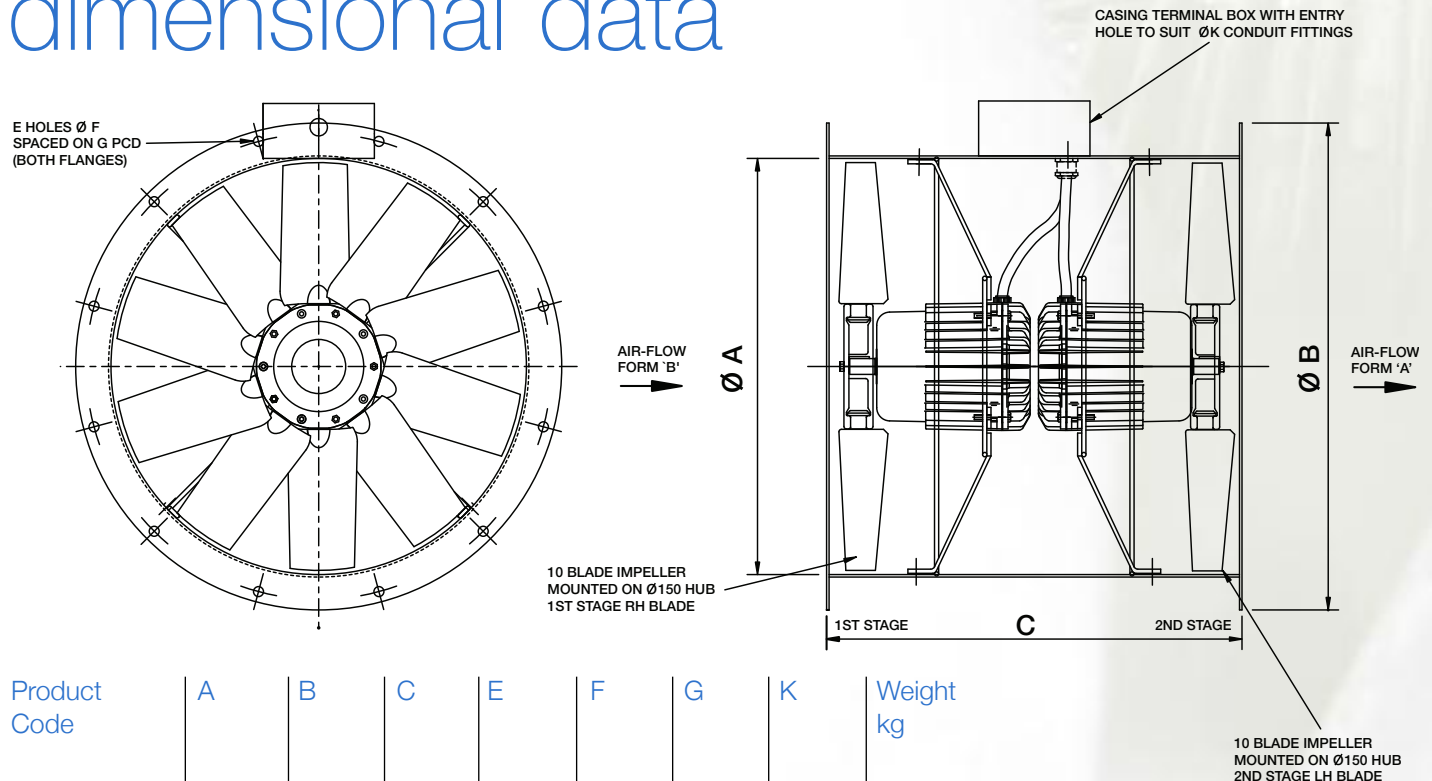

Product Code	A	B	C	E	F	G	K	Weight kg
SCPP450/4-1	450	530	430	8	12	500	20	35
SCPP500/4-1	500	585	500	12	12	560	20	55
SCPP560/4-1	560	645	500	12	12	620	20	60
SCPP630/4-1	630	715	500	12	12	690	20	70

# wiring diagrams

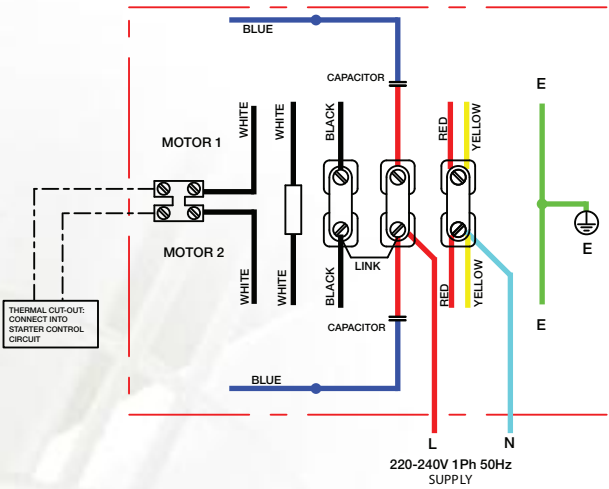

FIXED

CONNECTION

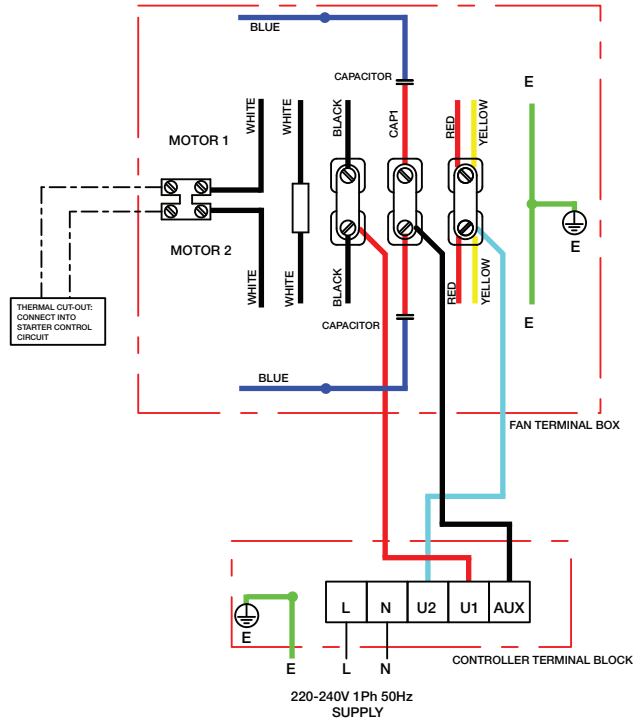

VARIABLE SPEED CONNECTION  
CONTROLLER TYPE: E L

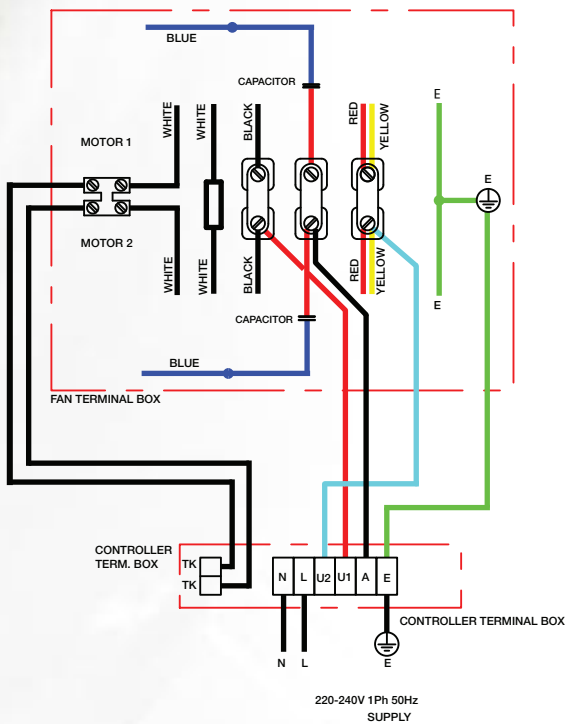

VARIABLE SPEED CONNECTION  
CONTROLLER TYPE: EL TK

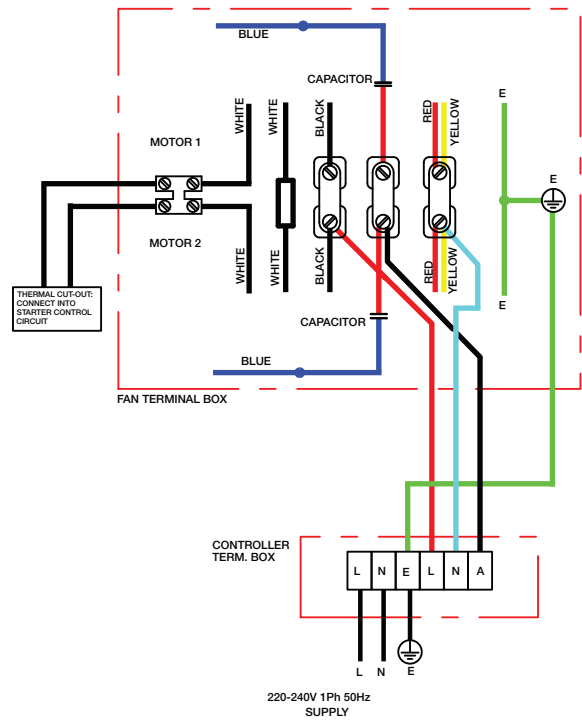

VARIABLE SPEED CONNECTION  
CONTROLLER TYPE: TC

# accessories

A comprehensive range of fan accessories are available. Compact Power Plus models are all available Ex-stock, as part of the ELTA 'Select' range, which means they can be delivered when you want them.

## impeller side guards

The impeller side guards are designed to protect against the rotating impeller parts. Guards are finger proof and bright acid zinc plated.

Product Code	NOM. DIA. A	B	Weight kg
078C-0450-C	450	470	2.0
078C-0500-C	500	520	2.5
078C-0560-C	560	585	3.0
078C-0600-C	630	655	3.5

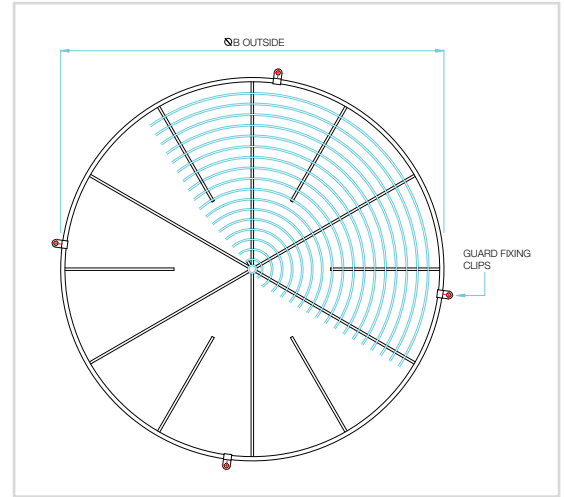

## flexible connectors

Designed to fit directly to the matching flange to provide a flexible inter-connection with any matched interface, for example ductwork. Flexible connectors are manufactured from PVC coated polyester, complete with banding clips.



Product Code	NOM. DIA. A	B	Weight kg
063-0450-MAN	450	150	3.0
063-0500-MAN	500	150	5.0
063-0550-MAN	560	150	5.5
063-0630-MAN	630	200	6.0

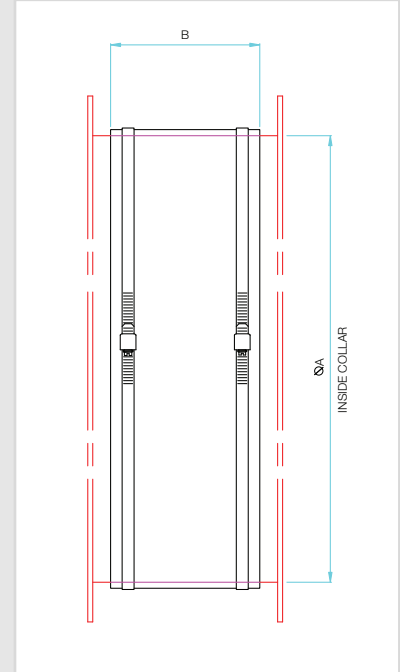

## mounting feet

The mounting feet are designed for free standing support, mounted directly onto the fan casing flange. Mounting feet are manufactured from pre-fabricated sheet steel, then hot dipped galvanized to BS 729.

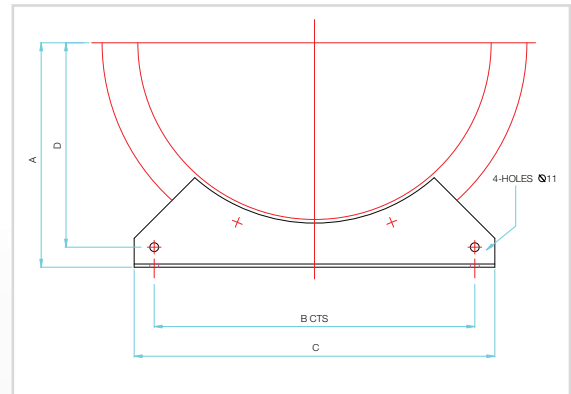
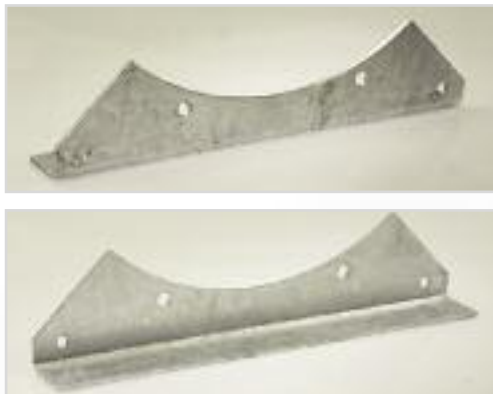

Product Code	Fan Dia	A	B	C	D	E	F	G	Weight kg
060B-0450	450	280	400	450	255	50	27.5	4	2.0
060B-0500	500	315	450	500	290	50	27.5	4	2.5
060B-0560	560	355	510	560	330	60	32	5	4.0
060B-0630	630	400	580	630	375	60	32	5	5.0

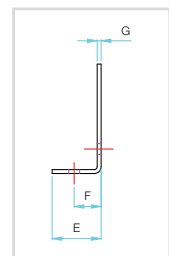

# matching flanges



The Matching flanges are designed to fit directly to the fan casing mounting flange to provide a coupling for a flexible collar, or an alternative fixing for any other matched inter-connection, for example, ducting.

Matching flanges are manufactured from pre-fabricated sheet steel, hot dipped galvanized to BS 729.

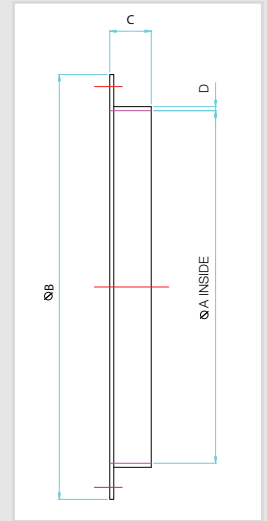

Product Code	A	B	C	D	Weight kg
061B-0450	450	530	40	1.5	2.2
061B-0500	500	585	45	2.0	2.6
061B-0560	560	645	45	2.0	3.0
061B-0630	630	715	45	2.0	3.4

# anti-vibration mounts

Anti-vibration mounts are designed to fit directly to mounting feet to assist in minimising noise in sensitive locations. All anti-vibration mounts are manufactured from rubber with steel inserts.

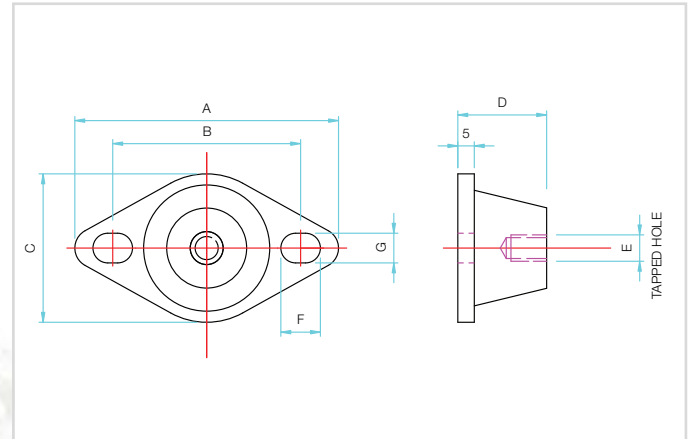

Product Code	A	B	C	D	E	F	G
S2, S2B	80	57	45	32	M8	12	9

# bell mouth inlets\*

These are designed to fit directly onto the fan casing inlet mounting flange to ensure a more efficient air entry path. Bell mouth inlets are manufactured from pre-fabricated sheet steel, then hot dipped galvanized to BS 729.

\*All bell mouth inlets are made to order.

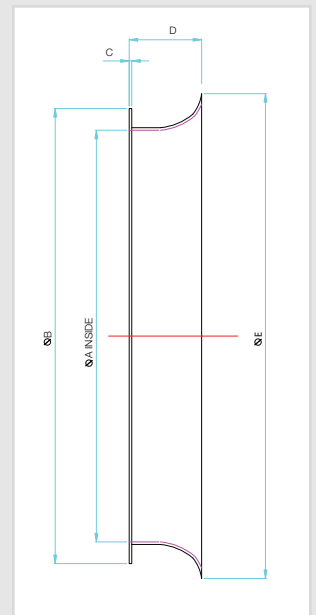

Product Code	Fan Dia A	B	C	D	E	Weight kg
241B-0450-BELL450	450	530	5	85	570	5.3
241B-0500-BELL500	500	585	5	93	640	6.2
241B-0560-BELL560	560	645	5	105	645	7.5
241B-0630-BELL630	630	715	5	105	800	9.0

# silencers

Silencers are specifically designed to be installed in air duct systems to control the air noise in the duct, or to control the intake/discharge noise levels. Available as either podded or unpodded silencers, they are rigidly constructed in sheet steel, with a highly absorbent sound attenuating material lining between the outer casing and inner perforated steel lining.

Silencer end faces have captive fasteners for direct mounting to the fan mounting flange. The pod, constructed from perforated sheet steel, has a sound absorbent infill.

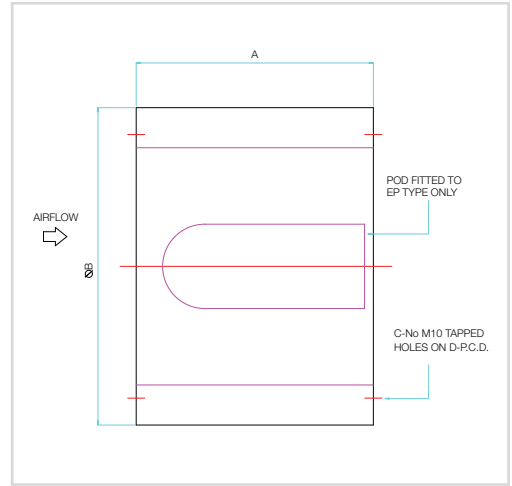

Product Code	Fan Dia	A 1D	A 2D	B	C	D
061B-0450	450	450	900	602	8	500
061B-0500	500	500	1000	653	12	560
061B-0560	560	560	1120	713	12	620
061B-0630	630	630	1260	785	12	690

Product Code	Weight kg				dBA Attenuation		ΔP (Pa)		dBA Attenuation		ΔP (Pa)
	1DENP	1DEP	2DENP	2DEP	1DENP	1DEP	1DEP	2DENP	2DEP	2DEP	
061B-0450	15	18	27	31	-9	-12	22	-15	-18	36	
061B-0500	18	22	32	37	-9	-14	28	-16	-20	45	
061B-0560	22	26	39	46	-10	-15	27	-16	-22	44	
061B-0630	26	32	48	57	-9	-16	31	-14	-25	50	

# non return dampers\*

These are butterfly type, air activated dampers, with a gravity closing action. Non Return Dampers are manufactured from pre-fabricated sheet steel, then hot dipped galvanized to BS 729.

\* All non return dampers are made to order. Please specify when ordering; mode of operation i.e. horizontal or vertical and airflow direction.

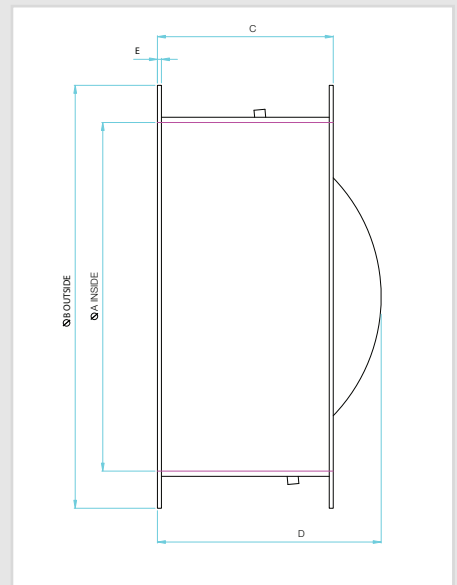

Product Code	Fan Dia A	B	C	D	E	Weight kg
019-0450-STD	450	530	220	280	3	14.5
019-0500-STD	500	585	220	315	3	16.5
019-0550-STD	560	645	220	375	3	20.0
019-0630-STD	630	715	250	420	3	22.5

**compact** by name  
**powerful** by performance



The Compact Power Plus - High on pressure, low on noise - which means a multitude of applications.

Four powerful sizes, 450mm, 500mm, 560mm and 630mm.

Bristling with features, Compact Power Plus oozes customer appeal.

Contact Elta Fans for more information or visit [eltafans.com](http://eltafans.com)

**COMPACT**  
**POWERPLUS**





**Elta Fans Ltd**

17 Barnes Wallis Road,  
Segensworth East Industrial Estate,  
Fareham, Hampshire, P015 5ST, United Kingdom.

Visit: [eltafans.com](http://eltafans.com)

e-mail: [mailbox@eltafans.co.uk](mailto:mailbox@eltafans.co.uk)

**Applied Technology:** Tel: +44 (0) 1489 566500 Fax: +44 (0) 1489 566555

**Building Services:** Tel: +44 (0) 1384 275800 Fax: +44 (0) 1384 275810

**Export:** Tel: +44 (0) 1489 566523 Fax: +44 (0) 1489 566543

**EF-SCCP-0806-01**